

The Future of Electrification

Robyn MacNamara – Programme Manager [Electrification & Fixed Plant]

Nia Watkins – Regional Asset Manager [Electrification]

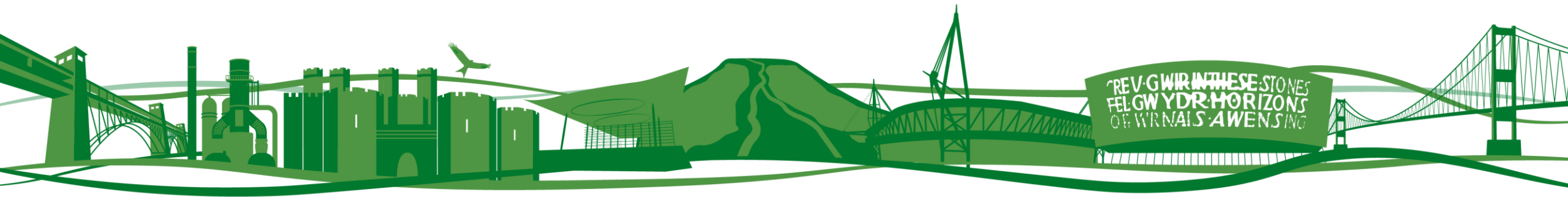

Wales and
Borders

Rail Transformation: Why it Matters

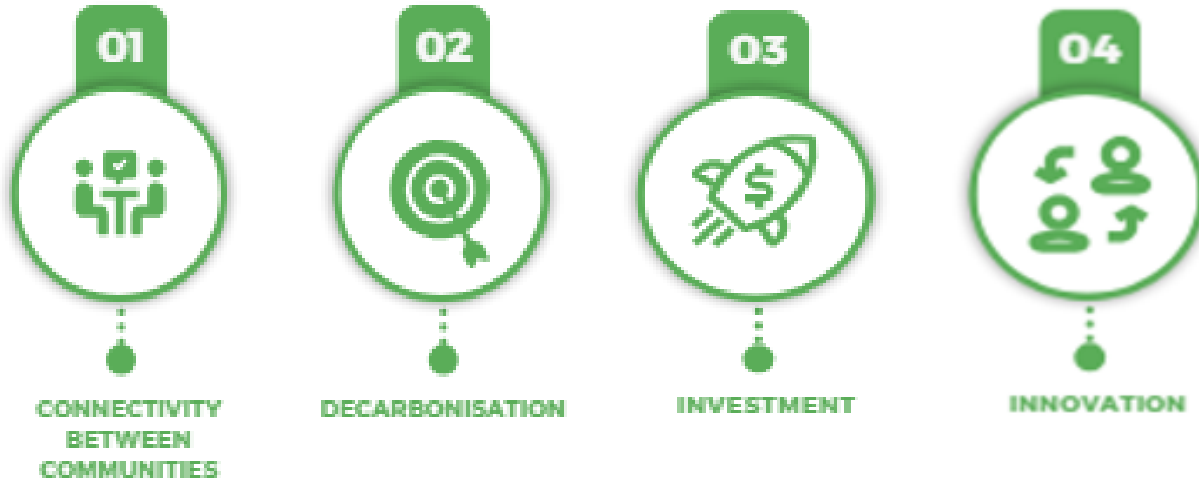

Current Network & Electrification Extent

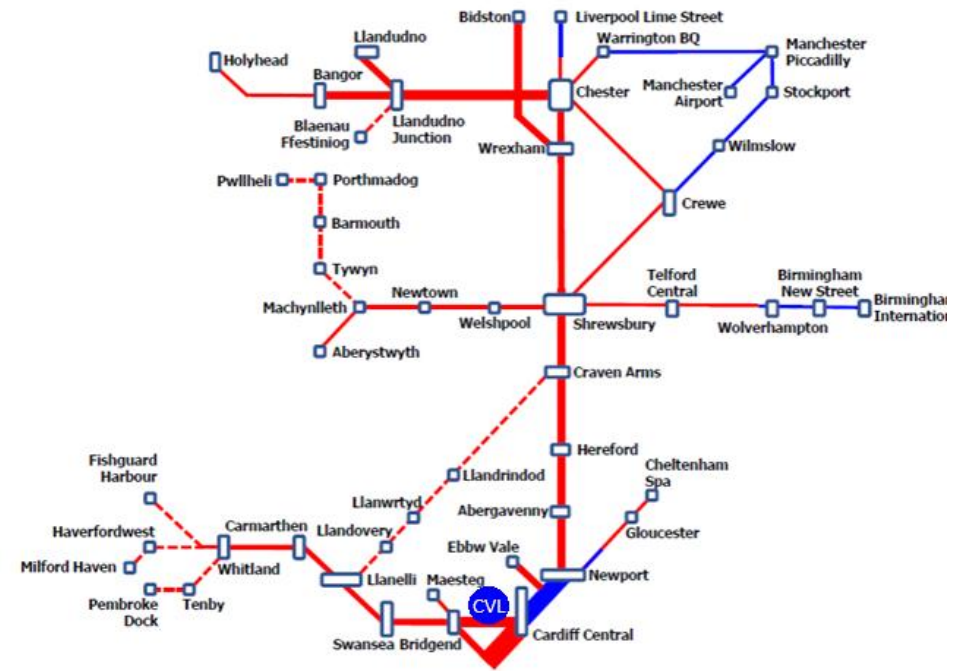

Battery Technology & Partial Electrification



Wales and
Borders

Cost Efficient Electrification

Composite Pantograph Horns



Voltage Clearance Control



Cost Efficient Electrification

Gradient Trials

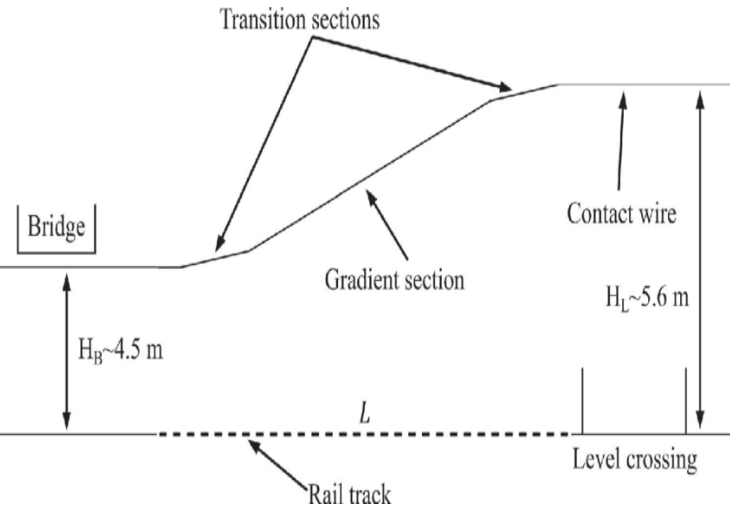

Bridge Parapet Risk Assessment



Digital Substations

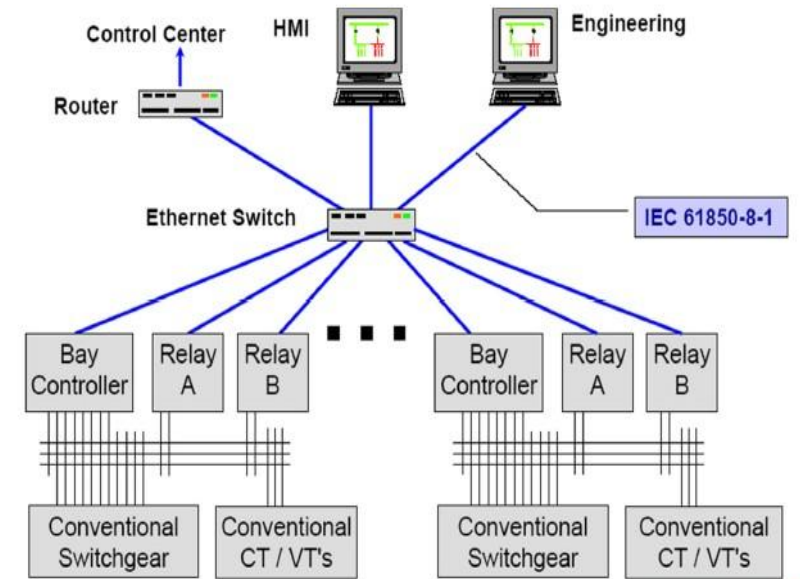

Collaboration: An Integrated Approach

Decarbonisation of the Wales and Borders rail network through integrated infrastructure and rolling stock improvements, supporting modal shift from road to rail. Providing affordable, high performing, and reliable solutions for passengers and freight.



Wales and
Borders



TRAFNIDIAETH CYMRU
TRANSPORT FOR WALES

Closing: A Greener, More Connected Wales

Meet Net-Zero Targets

Unlock Social Value in Rail



Deliver Cost-Efficient
Electrification

Create Economic Growth in
Communities.